

DINGS'

Precision Motion Specialist

Headquarter , CHINA

Jiangsu DINGS' Intelligent Control Technology Co., LTD

No. 2850 Luheng Road, Changzhou Economic Development Zone, Jiangsu Province, China

Phone : +86-519-85177826

Fax : +86-519-85177807

E-mail : info@dingsmotion.com

www.dingsmotion.com

Shenzhen Office

Room 1105, Block C, CIMC industry demonstration park, Qiaoming Road, Guangming district, Shenzhen City

E-mail : info@dingsmotion.com

International Office

DINGS' Motion USA

355 Cochrane Circle Morgan Hill, CA 95037

Phone : +1-408-612-4970

E-mail : sales@dingsmotionusa.com

www.dingsmotionusa.com

DINGS' Motion Europe

4 Avenue du Grand Trémoutier 44120 - Vertou - France

Phone : +33-(0)6-41-37-80-07

E-mail : sebastien@dingsmotion.com

<http://fr.dingsmotion.com>

DINGS' KOREA Co., Ltd

C-702, 158, Haneulmaeul-ro, Ilsandong-gu, Goyang-si, Gyeonggi-do, Republic of Korea

Phone : +82-31-994-0755

Fax : +82-70-4325-0755

E-mail : daniel@dingsmotion.com

www.dingsmotion.kr

DINGS' JAPAN

101, 2-27-18, Nishi-kojiya, Ota-ku, Tokyo 144-0034 JAPAN

Phone : +81-3-6811-1335

E-mail : tsukahara@dingsmotion.com

www.dingsmotion.com

■ This catalog is the sole property of DINGS' and without the written authorization of DINGS', any copy or forwarding is prohibited.

■ DINGS' reserves the right to make changes without further notification to any products herein to improve the reliability, function or design.

■ DINGS' reserves the final interpretation.

DINGS'

Precision Motion Specialist

BRUSHLESS DC MOTOR PRODUCT CATALOG

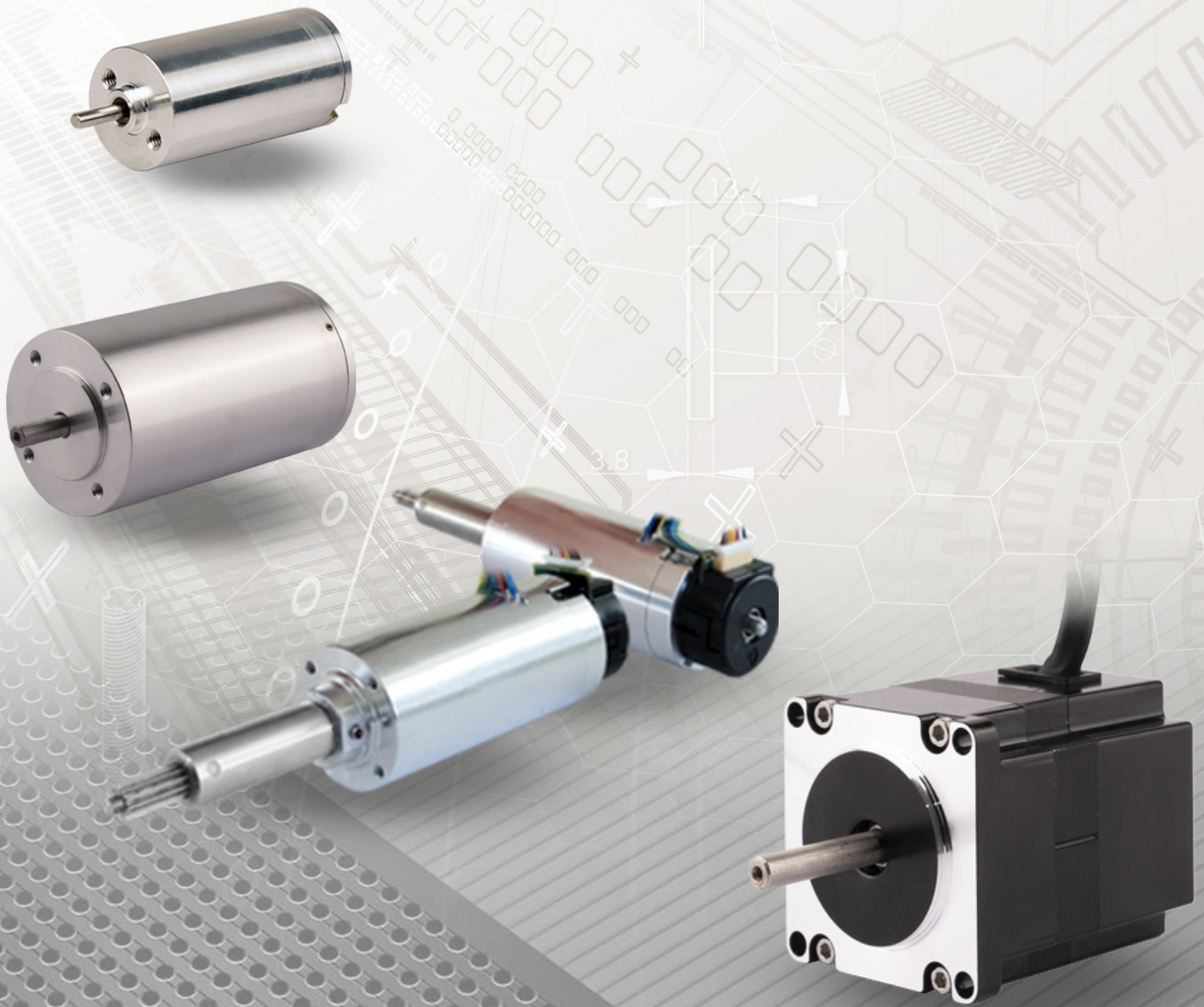

DINGS' provides 12 different sizes of Brushless DC motors have several advantages, including start and speed regulation, higher power density and over load capacity.

From 12mm to 130mm with power output ranging from 1.6W to 710W, DINGS' provides 12 frame sizes and according customer's requirements, higher capacity of Brushless DC Motors can be customized.

DINGS' Slotted Brushless DC Motors are classified as square flange and circular flange. Standard square flange of Brushless DC Motors can be used between stepper and AC Servo as low voltage DC Servo solution.

These Brushless DC Motors can run at high speed up to 3,000RPM without losing running torque as like conventional stepper solution.

Also compare to AC Servo, Brushless DC motor can be alternative as economic choice for wide range of applications as like Logistic Automation, Office automation, timing belt, packaging, textile industry, food/beverage and others.

Circular flange DINGS' slotted Brushless DC Motors can be running at 10,000RPM in general.

DINGS' Brushless DC Motors can be designed by aluminum or stainless steel casing according to application and also can be customized with gearbox, encoder and entire DINGS' Brushless DC Motors can be designed as linear actuators with lead or ball screw combination.



BRUSHLESS DC MOTOR

CONTENTS

Part number construction

12 mm

16 mm

22 mm

28 mm

36 mm

42 mm

57 mm

60 mm

86 mm

110 mm

130 mm

Precision planetary gearbox option

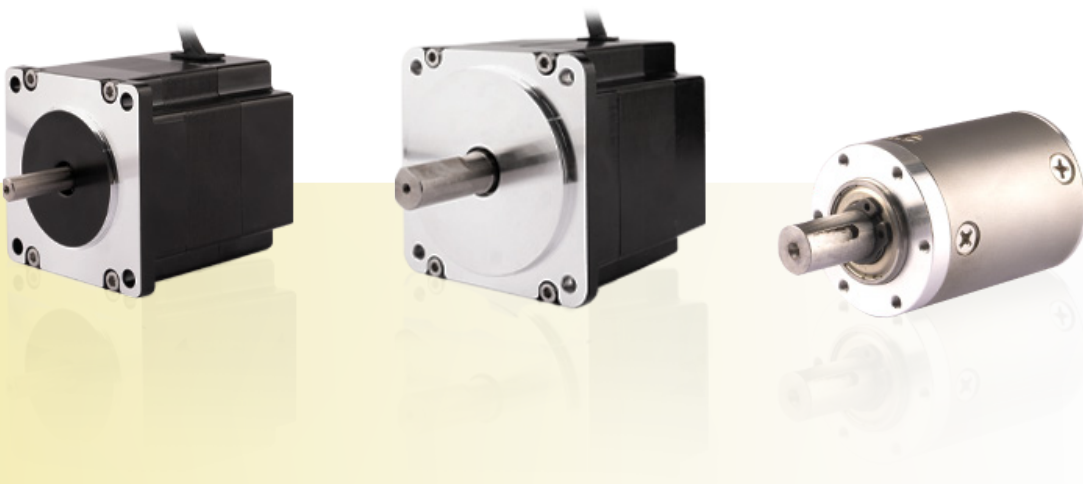

Part Number Construction

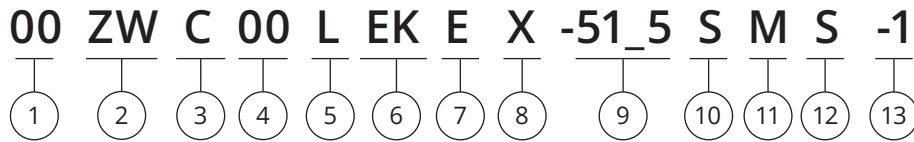

① Motor Size

Motor Size(mm)	12	16	22	28	36	42	57	60	86	110	130
----------------	----	----	----	----	----	----	----	----	----	-----	-----

② Product Name

ZW = Slotted Brushless DC Motor

③ Motor Shape

C = Circular Type

S = Square Type

④ Motor Length

Unit : mm

when the length involves decimal points, use "_" instead

⑤ Motor Casing

L = Aluminum

T = Stainless steel / Iron

X = Inorganic Shell

⑥ Option

EKX = Encoder (X = Encoder Resolution)

B = Brake

GX= Gearbox (X = Gear Ratio)

Note: When Options are not single,

please use in alphabetical order for example, "BEG"

⑦ Structure

E = External type

N = Non-Captive type

C = Electric Cylinder (Captive) type

K = Kaptive type

⑧ Lead Screw Code

Please refer to lead screw code selection table

⑨ Screw Length / Stroke

Kaptive = stroke distance

Non-captive = total length of screw

External = screw extension length from the mounting flange

⑩ Screw Surface Treatment

T = Teflon coating

S = Standard (No teflon coating)

⑪ End Machining

M = Metric

U = UNC

S = Smooth

C = Customize

N = None

⑫ Nut Style

S = Standard Flange Nut

A = Anti-Backlash Nut

C = Customized Nut

⑬ Customer Sequence Number

Example

Part Number

57ZWS40L-001

Description

General NEMA 23 size (57mm)
Square type Brushless DC motor
40mm motor length
With case
Customization No. 001

12mm BLDC

12ZWC30L-1 is very compact size but it has optimized magnetic circuit.

Brushless DC Motor with core winding has high torque density and multi-pole rotor can provide very strong and dynamic performance.

12ZWC30L-1 can reach Max. 10,000RPM.



Motor Characteristics

Motor part number		12ZWC30L-1
Body length (LT)	mm	30
Pole pair	-	2
Phase resistance	Ω	52.5
Phase inductance	mH	3.92
Winding connection method	-	Star shape
Insulation class	-	B
Duty type	-	S2
Commutation angle	-	120°
Insulation strength (Withstand voltage)	-	500VAC/1KHz/1mA/1s
Insulation resistance	-	100 MOhm 20C
Weight	g	18
Rated voltage	V	24
Rated power	W	1.6
Rated torque	mN·m	2
Rated speed	RPM	7700
Rated current	A	0.11
No load speed	RPM	10000
No load current	A	0.035
Motor efficiency	%	60
Noise (Ambient noise 20db, test distance 1m)	dB	< 50
Enclosure - Ambient thermal resistance	K/W	0.96
Ambient temperature	°C	20
Maximum winding temperature	°C	94
Torque constant	N·m/A	0.018
Back-EMF constant / Effective value	V/Krpm	1.895
Peak torque	mN·m	3
Peak current	A	0.33
Inertia moment	g·cm ²	0.18

12mm BLDC

Dimensional Drawings

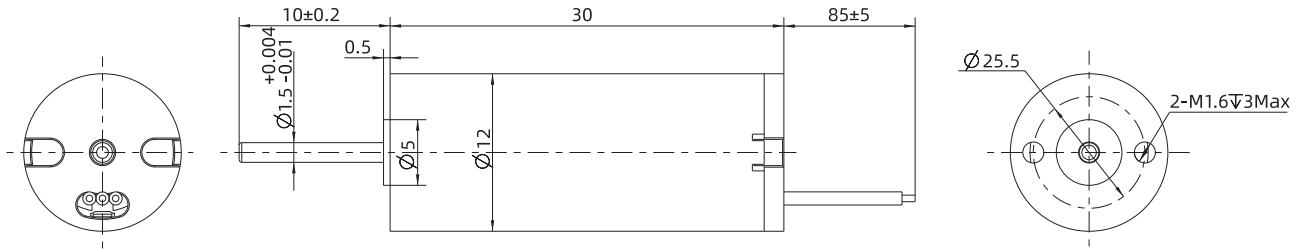

Lead-out type	Lead-out color	Function
UL3265 AWG26	Yellow	U phase
	Green	V phase
	Blue	W phase

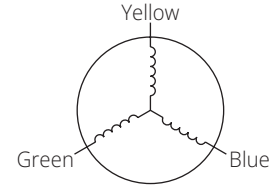

Torque Performance Curves

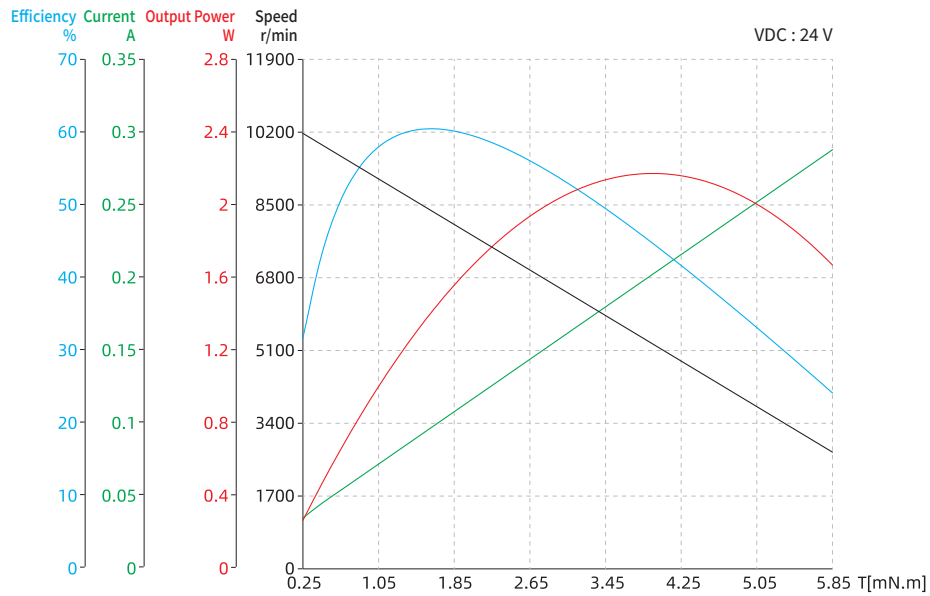

16mm BLDC

16ZWC32L-1 is very compact size but it has optimized magnetic circuit.

Brushless DC Motor with core winding has high torque density and multi-pole rotor can provide very strong and dynamic performance.

16ZWC32L-1 can reach Max. 16,300RPM.



Motor Characteristics

Motor part number		16ZWC32L-1
Body length (LT)	mm	32±0.3
Pole pair	-	2
Phase resistance	Ω	6.5
Phase inductance	mH	0.78
Winding connection method	-	Star shape
Insulation class	-	B
Duty type	-	S2
Feedback method	-	Hall sensors
Commutation angle	-	120°
Insulation strength (Withstand voltage)	-	500VAC/1KHz/1mA/1s
Insulation resistance	-	100 MOhm 20C
Weight	g	25.5
Rated voltage	V	24
Rated power	W	9.2
Rated torque	N·m	0.007
Rated speed	RPM	12600
Rated current	A	0.65
No load speed	RPM	16300
No load current	A	0.22
Motor efficiency	%	71.6
Static torque	mN·m	4.5
Noise (Ambient noise 20db, test distance 1m)	dB	< 50
Enclosure - Ambient thermal resistance	K/W	0.9
Ambient temperature	°C	25
Maximum winding temperature	°C	68.5
Torque constant	N·m/A	0.011
Back-EMF constant / Effective value	V/Krpm	1.25
Peak torque	N·m	0.021
Peak current	A	1.95
Inertia moment	g·cm ²	0.45

16mm BLDC

Dimensional Drawings

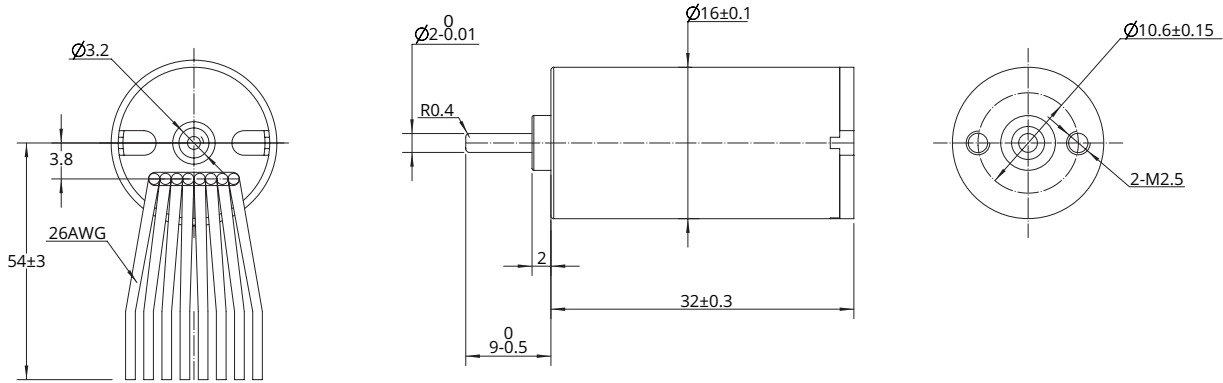

Lead-out type	Lead-out color	Function
UL3265 AWG26	Yellow	Hall U (Hu)
	Green	Hall V (Hv)
	Blue	Hall W (Hw)
	Red	Hall power supply positive (Vcc)
	Black	Hall power supply negative (GND)
UL3265 AWG26	Gray	U phase
	White	V phase
	Brown	W phase

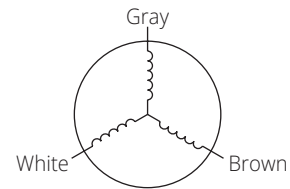
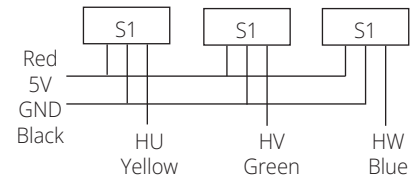

Torque Performance Curves

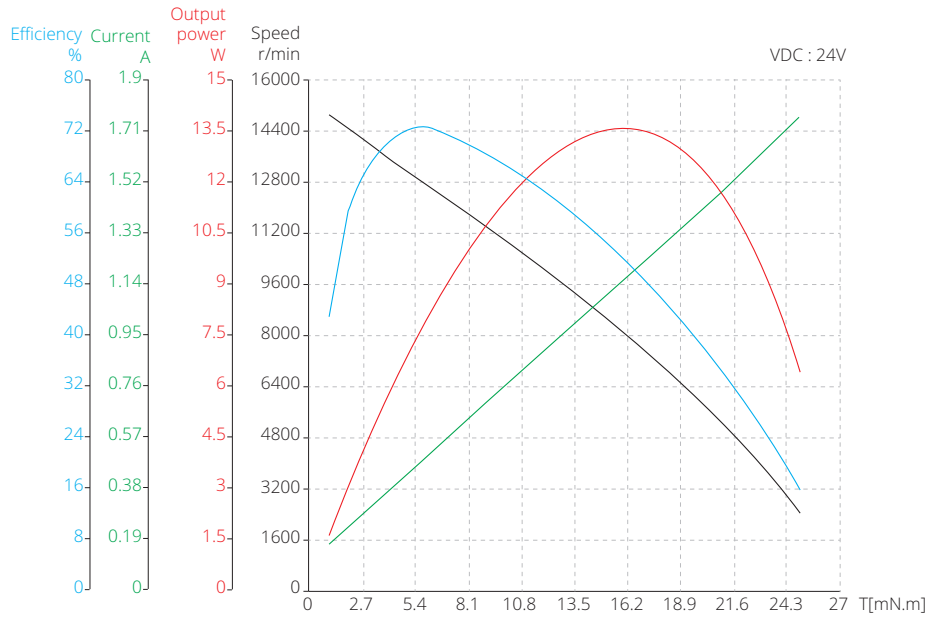

22mm BLDC

22mm Brushless DC Motor has Max. 0.019N·m rated torque and it can generate 19.9W capacity of rated power.

22mm motor has Star winding connection and 2 pole pairs motor with Hall sensors feed back method as standard.

In addition, and gearbox and incremental encoder is available.



Motor Characteristics

Motor part number		22ZWC48L-1
Body length (LT)	mm	47±0.5
Pole pair	-	2
Phase resistance	Ω	3.053
Phase inductance	mH	0.54
Winding connection method	-	Star shape
Insulation class	-	B
Duty type	-	S2
Feedback method	-	Hall sensors
Commutation angle	-	120°
Insulation strength (Withstand voltage)	-	500VAC/1KHz/1mA/1s
Insulation resistance	-	100 MOhm 20C
Weight	g	200
Rated voltage	V	24
Rated power	W	19.9
Rated torque	N·m	0.019
Rated speed	RPM	10000
Rated current	A	1.2
No load speed	RPM	12000
No load current	A	0.24
Motor efficiency	%	70
Static torque	mN·m	3.42
Noise (Ambient noise 20db, test distance 1m)	dB	< 50
Enclosure - Ambient thermal resistance	K/W	0.85
Ambient temperature	°C	25
Maximum winding temperature	°C	75
Torque constant	N·m/A	0.016
Back-EMF constant / Effective value	V/Krpm	1.67
Peak torque	N·m	0.057
Peak current	A	3.6
Inertia moment	g·cm ²	1.1

22mm BLDC

Dimensional Drawings

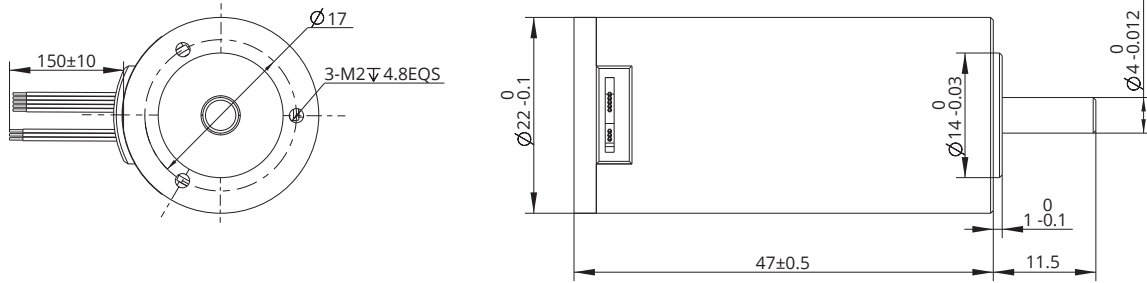

Lead-out type	Lead-out color	Function
UL3265 AWG26	Gray	Hall U (Hu)
	White	Hall V (Hv)
	Brown	Hall W (Hw)
	Red	Hall power supply positive (Vcc)
	Black	Hall power supply negative (GND)
UL3265 AWG26	Yellow	U phase
	Green	V phase
	Blue	W phase

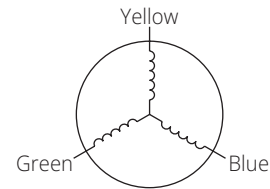
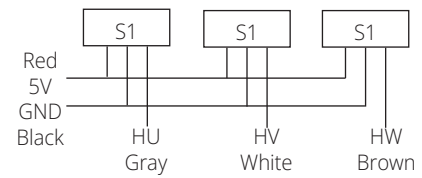

Torque Performance Curves

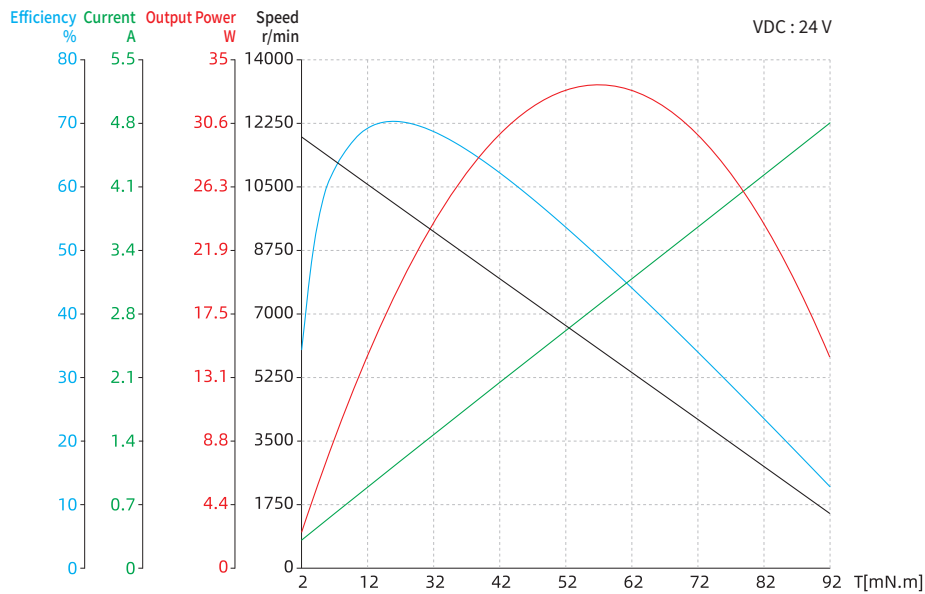

28mm BLDC

28mm Brushless DC Motor has Max. 0.05N·m rated torque and it can generate 52.4W capacity of rated power.

28mm motor has Star winding connection and 2 pole pairs motor with Hall sensors feed back method as standard.

In addition, and gearbox and incremental encoder is available.



Motor Characteristics

Motor part number		28ZWC58L-1
Body length (LT)	mm	57.5
Pole pair	-	2
Phase resistance	Ω	0.676
Phase inductance	mH	0.2
Winding connection method	-	Star shape
Insulation class	-	B
Duty type	-	S2
Feedback method	-	Hall sensors
Commutation angle	-	120°
Insulation strength (Withstand voltage)	-	500VAC/1KHz/1mA/1s
Insulation resistance	-	100 MOhm 20C
Weight	g	300
Rated voltage	V	24
Rated power	W	52.4
Rated torque	N·m	0.05
Rated speed	RPM	10000
Rated current	A	3
No load speed	RPM	12000
No load current	A	0.5
Motor efficiency	%	77
Static torque	mN·m	12.8
Noise (Ambient noise 20db, test distance 1m)	dB	< 50
Enclosure - Ambient thermal resistance	K/W	0.38
Ambient temperature	°C	25
Maximum winding temperature	°C	75
Torque constant	N·m/A	0.017
Back-EMF constant / Effective value	V/Krpm	1.78
Peak torque	N·m	0.15
Peak current	A	9
Inertia moment	Kg·cm ²	0.011

28mm BLDC

Dimensional Drawings

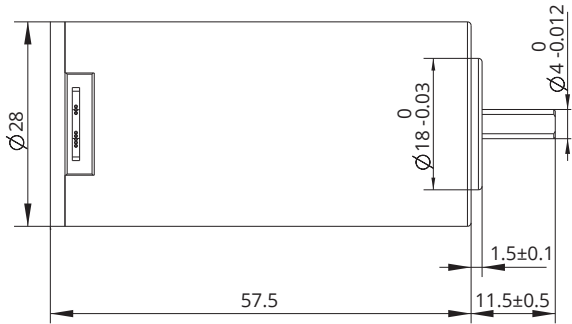
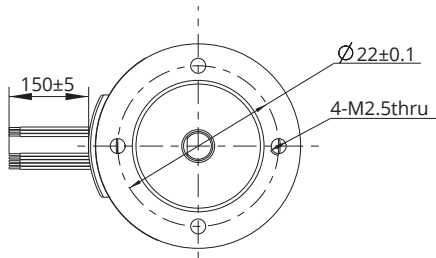

Lead-out type	Lead-out color	Function
UL3265 AWG26	Yellow	Hall U (Hu)
	Green	Hall V (Hv)
	Blue	Hall W (Hw)
	Red	Hall power supply positive (Vcc)
	Black	Hall power supply negative (GND)
UL3265 AWG22	Yellow	U phase
	Green	V phase
	Blue	W phase

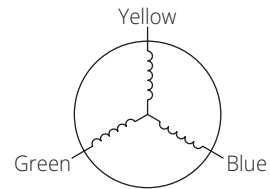
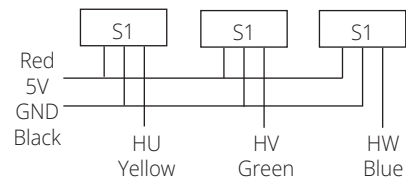

Torque Performance Curves

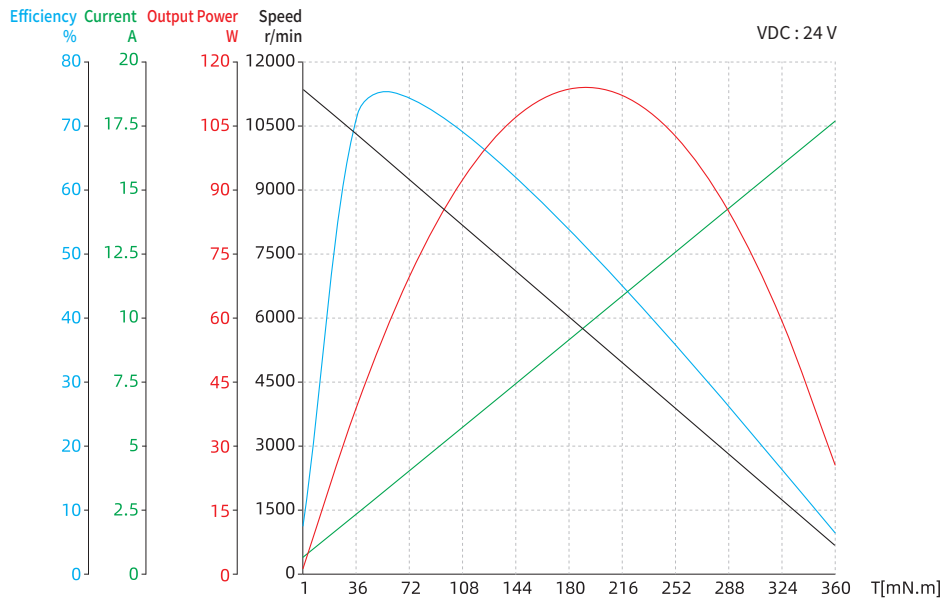

36mm BLDC

36mm Brushless DC Motor has Max. 0.125N·m rated torque and it can generate 130.9W capacity of rated power.

36mm motor has Star winding connection and 2 pole pairs motor with Hall sensors feed back method as standard.

In addition, and gearbox and incremental encoder is available.



Motor Characteristics

Motor part number		36ZWC72L-1
Body length (LT)	mm	71.5±0.5
Pole pair	-	2
Phase resistance	Ω	0.67
Phase inductance	mH	0.37
Winding connection method	-	Star shape
Insulation class	-	B
Duty type	-	S2
Feedback method	-	Hall sensors
Commutation angle	-	120°
Insulation strength (Withstand voltage)	-	500VAC/1KHz/1mA/1s
Insulation resistance	-	100 MOhm 20C
Weight	g	600
Rated voltage	V	48
Rated power	W	130.9
Rated torque	N·m	0.125
Rated speed	RPM	10000
Rated current	A	3.6
No load speed	RPM	12000
No load current	A	0.5
Motor efficiency	%	80
Static torque	mN·m	35.5
Noise (Ambient noise 20db, test distance 1m)	dB	< 50
Enclosure - Ambient thermal resistance	K/W	0.24
Ambient temperature	°C	25
Maximum winding temperature	°C	75
Torque constant	N·m/A	0.035
Back-EMF constant / Effective value	V/Krpm	3.67
Peak torque	N·m	0.375
Peak current	A	10.8
Inertia moment	Kg·cm ²	0.037

36mm BLDC

Dimensional Drawings

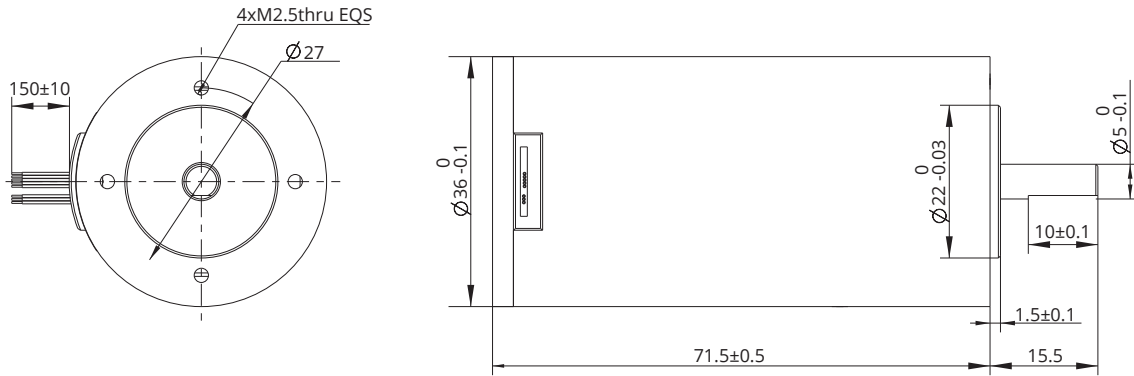

Lead-out type	Lead-out color	Function
UL3265 AWG26	Yellow	Hall U (Hu)
	Green	Hall V (Hv)
	Blue	Hall W (Hw)
	Red	Hall power supply positive (Vcc)
	Black	Hall power supply negative (GND)
UL3265 AWG22	Yellow	U phase
	Green	V phase
	Blue	W phase

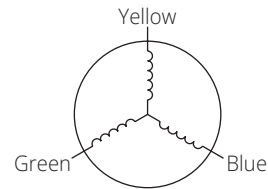
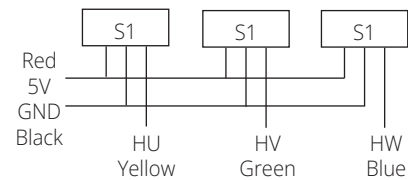

Torque Performance Curves

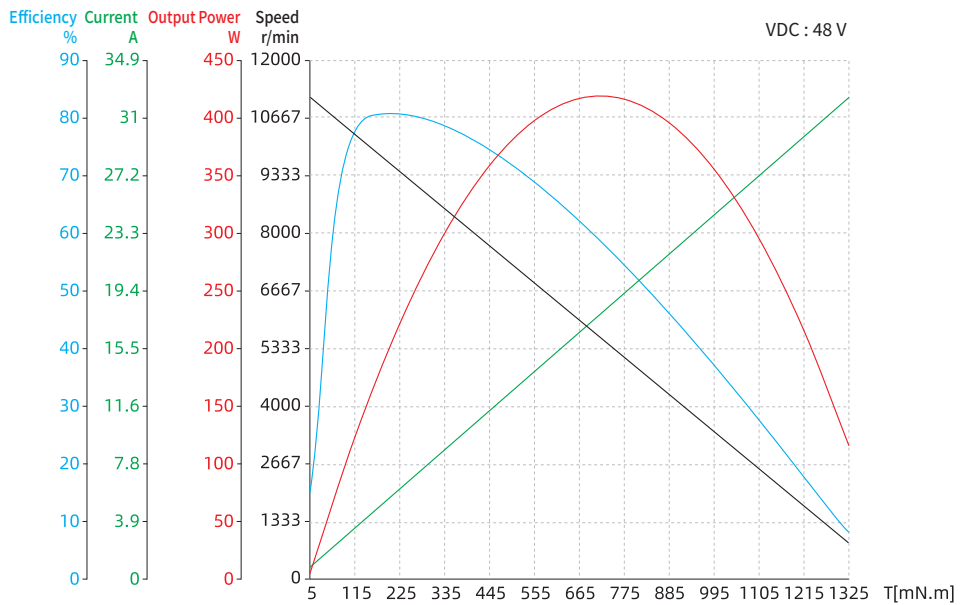

42mm BLDC

42mm Brushless DC Motor has Max. 0.2N·m rated torque and it can generate 209.4W capacity of rated power.

42mm motors have Star winding connection and 2 or 5 pole pairs motor with Hall sensors feed back method as standard.

In addition, and gearbox and incremental encoder is available.



Motor Characteristics

Motor part number		42ZWC75L-1	42ZWC75L-2	42ZWS50X-1	42ZWS63X-1	42ZWS75X-1
Body length (LT)	mm	73±0.5	73±0.5	50±1	63±1	75±1
Pole pair	-	2	2	5	5	5
Phase resistance	Ω	0.24	0.19	2.482	1.261	0.987
Phase inductance	mH	0.15	0.12	1.062	0.586	0.434
Winding connection method	-	Star shape	Star shape	Star shape	Star shape	Star shape
Insulation class	-	B	B	B	B	B
Duty type	-	S2	S2	S2	S2	S2
Feedback method	-	Hall sensors	Hall sensors	Hall sensors	Hall sensors	Hall sensors
Commutation angle	-	120°	120°	120°	120°	120°
Insulation strength (Withstand voltage)	-	500VAC/1KHz/ 1mA/1s	500VAC/1KHz/ 1mA/1s	500VAC/1KHz/ 1mA/1s	500VAC/1KHz/ 1mA/1s	500VAC/1KHz/ 1mA/1s
Insulation resistance	-	100 MOhm 20C	100 MOhm 20C	100 MOhm 20C	100 MOhm 20C	100 MOhm 20C
Weight	g	800	800	260	380	500
Rated voltage	V	48	24	24	24	24
Rated power	W	209.4	83	19.6	39.3	58.1
Rated torque	N·m	0.2	0.08	0.0625	0.125	0.185
Rated speed	RPM	10000	10000	3000	3000	3000
Rated current	A	5.5	4.3	1.2	2.4	3.6
No load speed	RPM	12000	12000	4000	4000	4000
No load current	A	0.86	0.7	0.15	0.3	0.45
Motor efficiency	%	80	80	72	77.6	76
Noise (Ambient noise 20db, test distance 1m)	dB	< 50	< 50	< 50	< 50	< 50
Enclosure - Ambient thermal resistance	K/W	0.085	0.25	0.75	0.38	0.25
Ambient temperature	°C	25	25	31.3	31.3	31.3
Maximum winding temperature	°C	75	75	68.5	68.5	68.5
Torque constant	N·m/A	0.036	0.019	0.052	0.052	0.051
Back-EMF constant / Effective value	V/Krpm	3.77	1.99	5.44	5.44	5.44
Peak torque	N·m	0.6	0.24	0.1875	0.375	0.555
Peak current	A	16.5	12.9	3.6	7.2	10.8
Inertia moment	Kg·cm ²	0.084	0.084	0.05	0.1	0.15

For stroke customization, please contact DINGS' or local representative.

42mm BLDC

- Dimensional Drawings
- 42ZWC75L

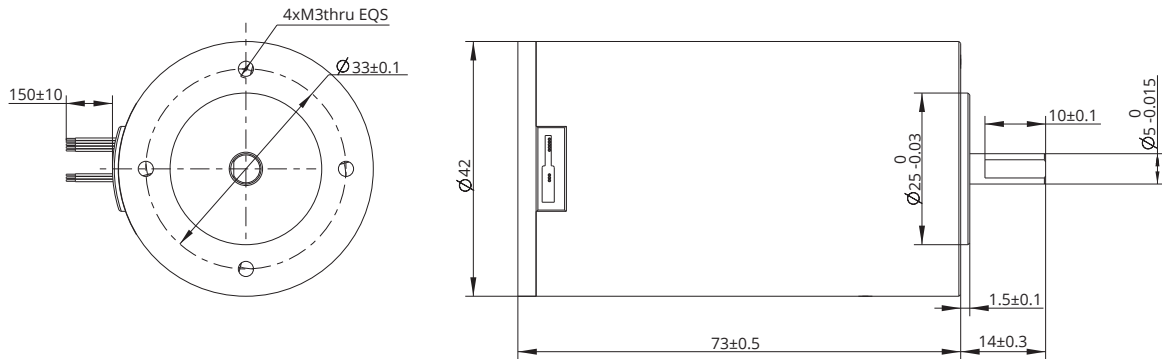

Lead-out type	Lead-out color	Function
UL3265 AWG26	Yellow	Hall U (Hu)
	Green	Hall V (Hv)
	Blue	Hall W (Hw)
	Red	Hall power supply positive (Vcc)
	Black	Hall power supply negative (GND)
UL3265 AWG22	Yellow	U phase
	Green	V phase
	Blue	W phase

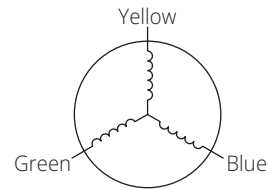
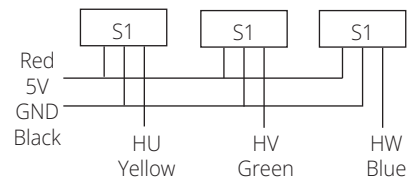

- 42ZWS**X

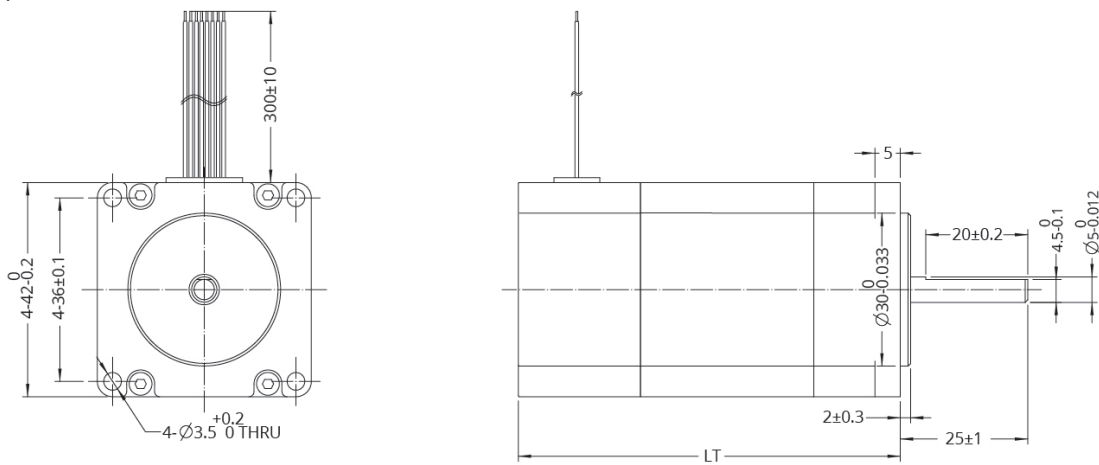

Lead-out type	Lead-out color	Function
UL3265 AWG26	Yellow	Hall U (Hu)
	Green	Hall V (Hv)
	Blue	Hall W (Hw)
	Red	Hall power supply positive (Vcc)
	Black	Hall power supply negative (GND)
UL3265 AWG22	Yellow	U phase
	Green	V phase
	Blue	W phase

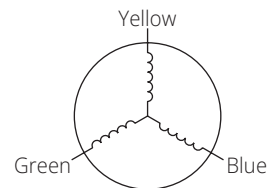
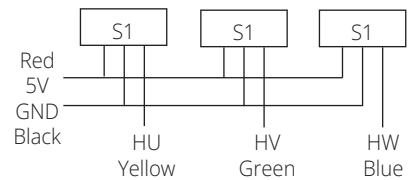

42mm BLDC

Torque Performance Curves

42ZWC75L-1

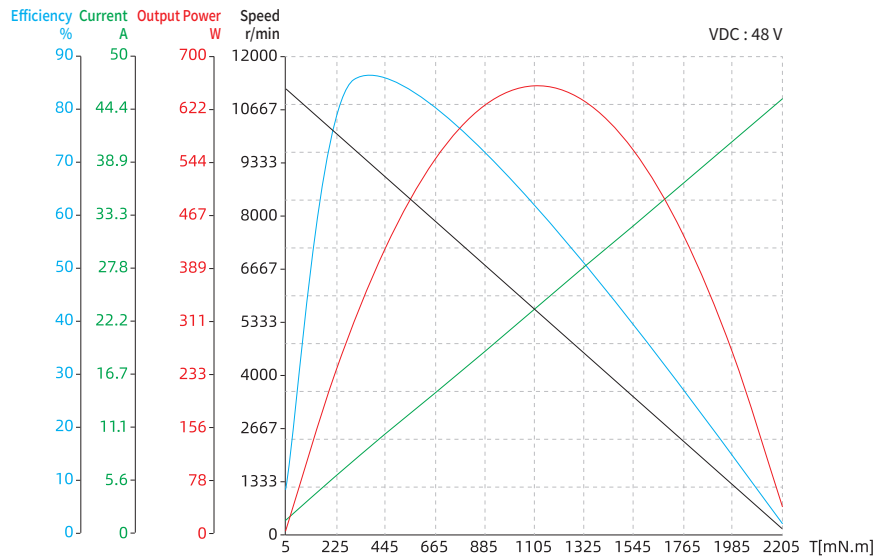

42ZWC75L-2

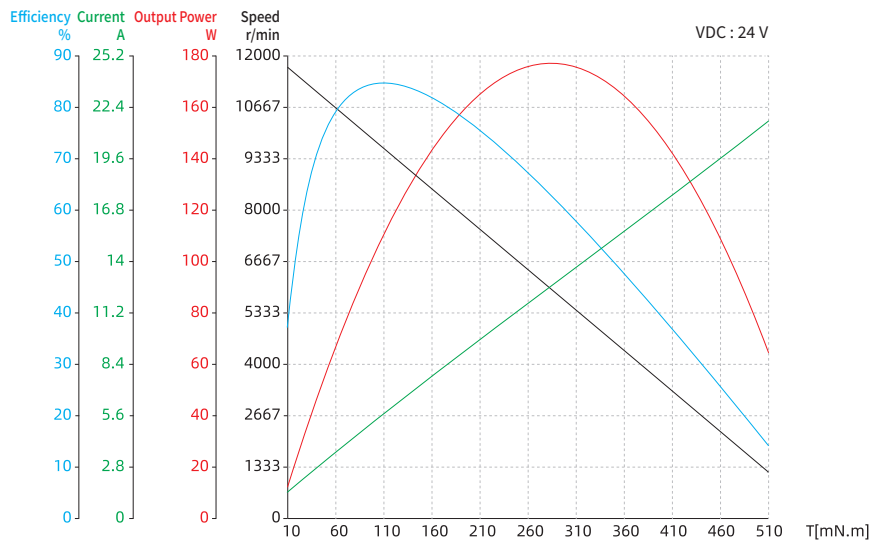

42mm BLDC

● 42ZWS50X-1

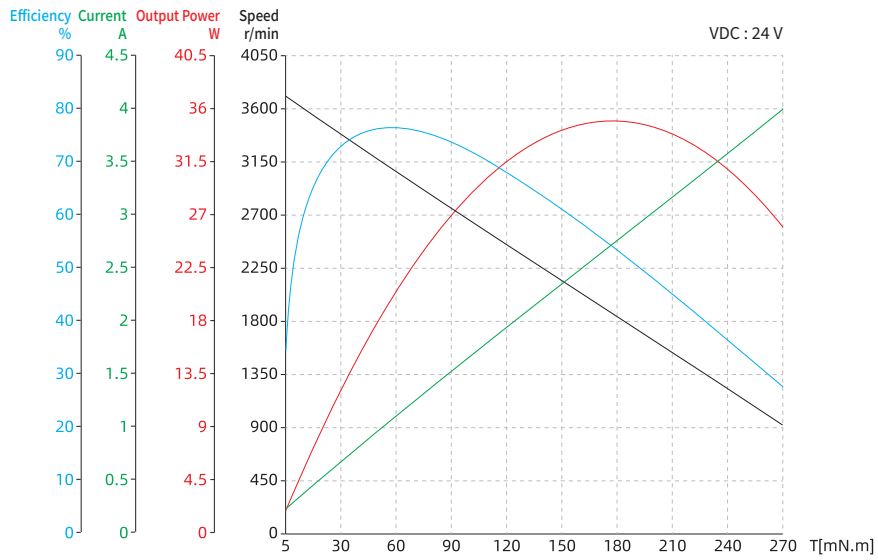

● 42ZWS63X-1

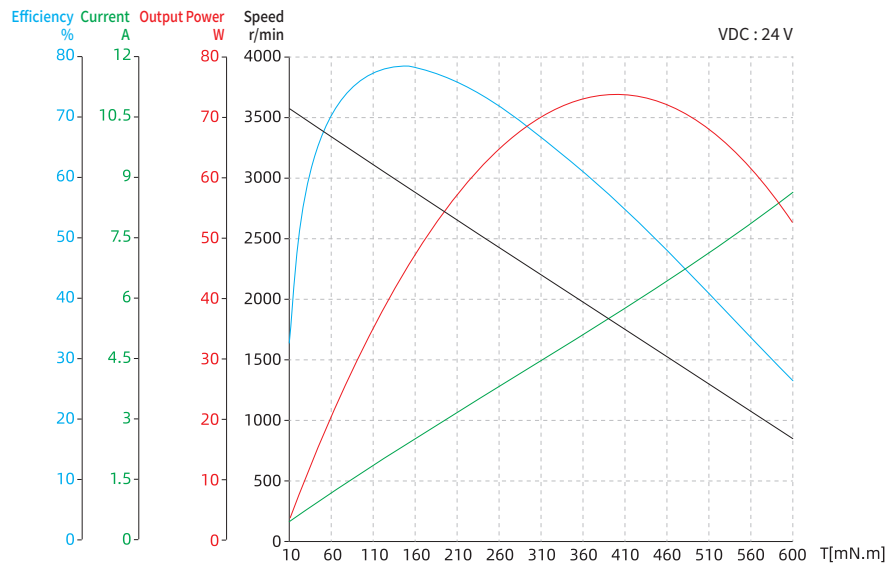

● 42ZWS75X-1

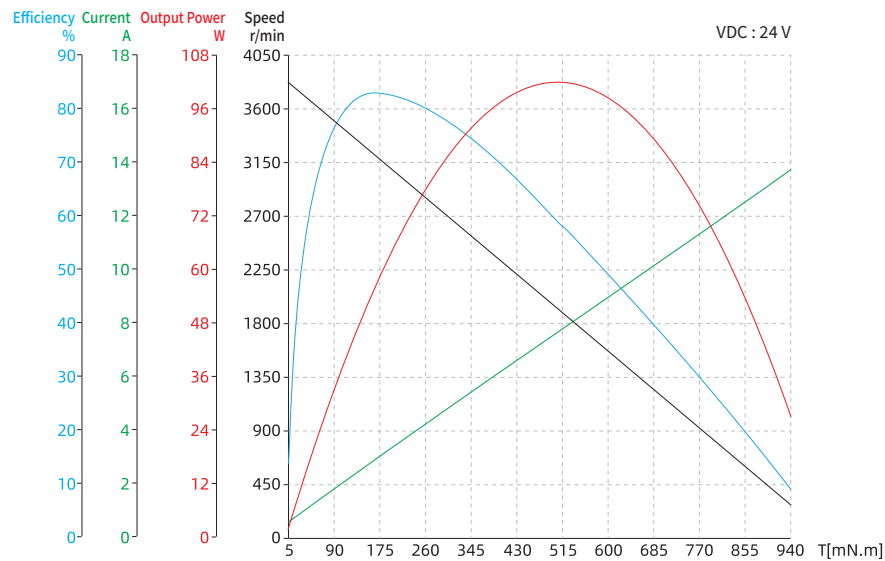

57mm BLDC

57mm Brushless DC Motor has Max. 0.33N·m rated torque and it can generate 103.7W capacity of rated power.

57mm motors have Star winding connection and 5 pole pairs motors with Hall sensors feed back method as standard.

In addition, gearbox and incremental encoder is available.



Motor Characteristics

Motor part number		57ZWS50X-1	57ZWS63X-1	57ZWS75X-1
Body length (LT)	mm	50±1	63±1	75±1
Pole pair	-	5	5	5
Phase resistance	Ω	0.958	0.473	0.301
Phase inductance	mH	0.742	0.357	0.205
Winding connection method	-	Star shape	Star shape	Star shape
Insulation class	-	B	B	B
Duty type	-	S1	S1	S1
Feedback method	-	Hall sensors	Hall sensors	Hall sensors
Commutation angle	-	120°	120°	120°
Insulation strength (Withstand voltage)	-	500VAC/1KHz/ 1mA/1s	500VAC/1KHz/ 1mA/1s	500VAC/1KHz/ 1mA/1s
Insulation resistance	-	100 MOhm 20C	100 MOhm 20C	100 MOhm 20C
Weight	kg	0.42	0.65	0.87
Rated voltage	V	24	24	24
Rated power	W	37.4	69.1	103.7
Rated torque	N·m	0.119	0.22	0.33
Rated speed	RPM	3000	3000	3000
Rated current	A	2.2	4.1	6
No load speed	RPM	4000	4000	4000
No load current	A	0.25	0.5	0.75
Motor efficiency	%	78	80	82
Noise (Ambient noise 20db, test distance 1m)	dB	< 50	< 50	< 50
Enclosure - Ambient thermal resistance	K/W	0.53	0.27	0.18
Ambient temperature	°C	29	29	29
Maximum winding temperature	°C	77.4	77.4	77.4
Torque constant	N·m/A	0.054	0.054	0.055
Back-EMF constant / Effective value	V/Krpm	5.66	5.66	5.66
Peak torque	N·m	0.357	0.66	0.99
Peak current	A	6.6	12.3	18
Inertia moment	Kg·cm ²	0.19	0.38	0.56

57mm BLDC

Dimensional Drawings

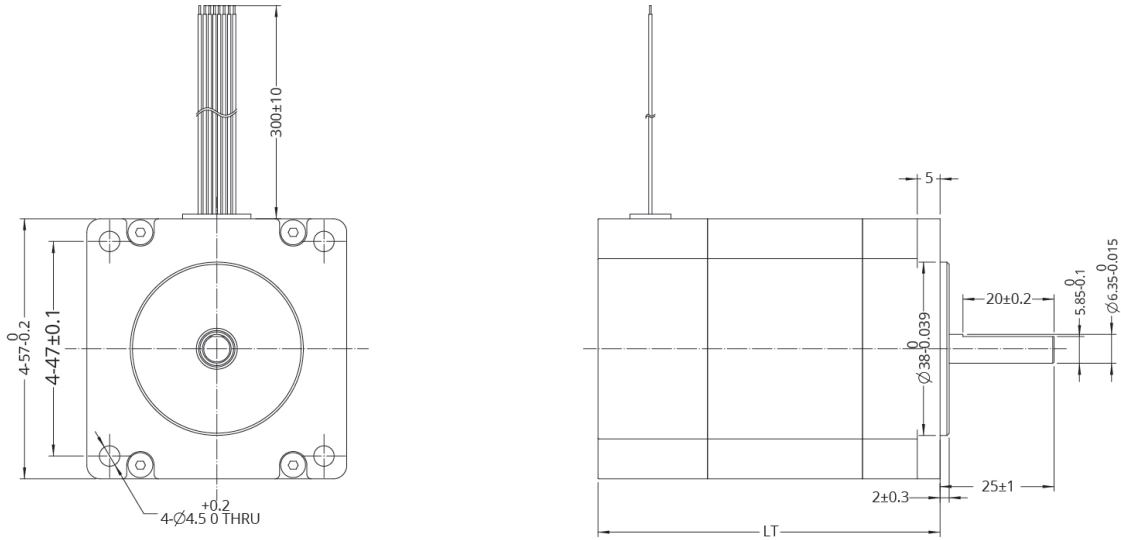

Lead-out type	Lead-out color	Function
UL3265 AWG26	Yellow	Hall U (Hu)
	Green	Hall V (Hv)
	Blue	Hall W (Hw)
	Red	Hall power supply positive (Vcc)
	Black	Hall power supply negative (GND)
UL3265 AWG18	Yellow	U phase
	Green	V phase
	Blue	W phase

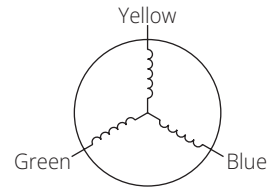
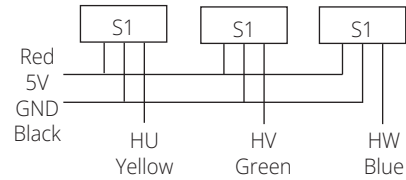

Torque Performance Curves

57ZWS50X-1

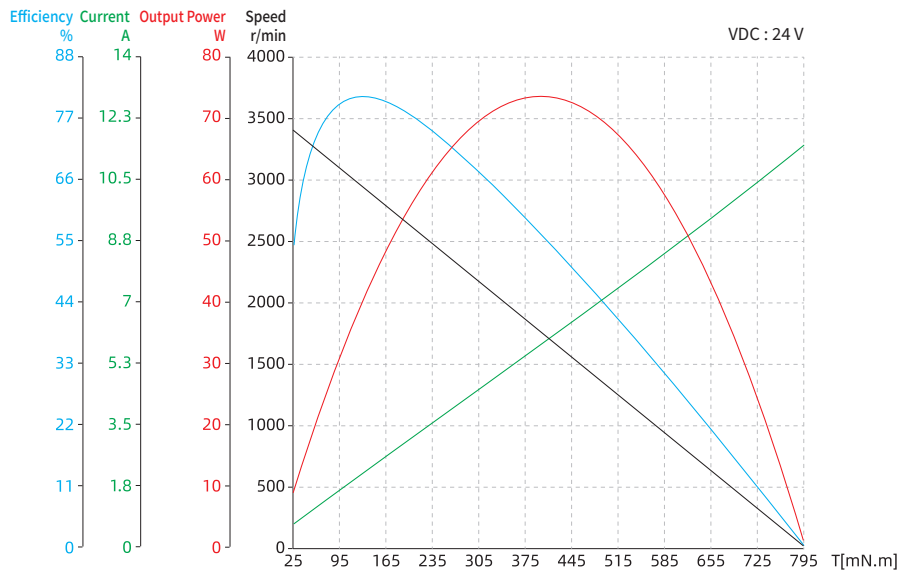

57mm BLDC

● 57ZWS63X-1

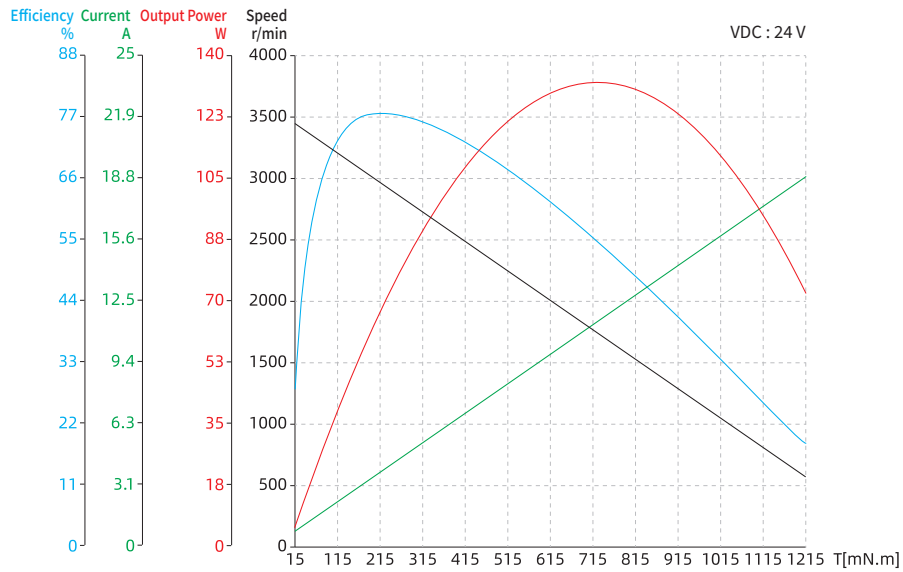

● 57ZWS75X-1

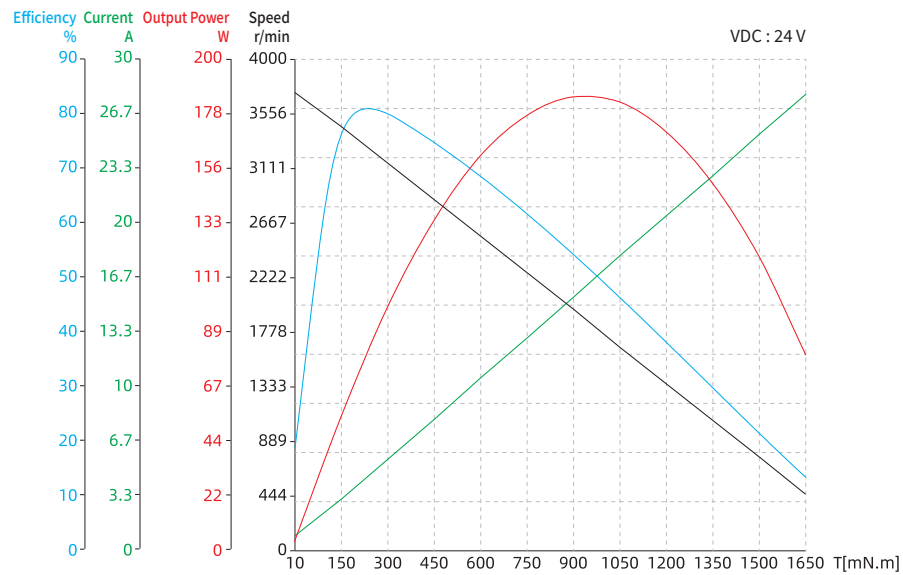

60mm BLDC

60mm Brushless DC Motor has Max. 0.46N·m rated torque and it can generate 144.5W capacity of rated power.

60mm motors have Star winding connection and 5 pole pairs motors with Hall sensors feed back method as standard.

In addition, gearbox and incremental encoder is available.



Motor Characteristics

Motor part number		60ZWS50X-1	60ZWS63X-1	60ZWS75X-1
Body length (LT)	mm	50±1	63±1	75±1
Pole pair	-	5	5	5
Phase resistance	Ω	0.886	0.334	0.233
Phase inductance	mH	0.682	0.305	0.183
Winding connection method	-	Star shape	Star shape	Star shape
Insulation class	-	B	B	B
Duty type	-	S1	S1	S1
Feedback method	-	Hall sensors	Hall sensors	Hall sensors
Commutation angle	-	120°	120°	120°
Insulation strength (Withstand voltage)	-	500VAC/1KHz/ 1mA/1s	500VAC/1KHz/ 1mA/1s	500VAC/1KHz/ 1mA/1s
Insulation resistance	-	100 MOhm 20C	100 MOhm 20C	100 MOhm 20C
Weight	kg	0.51	0.77	1
Rated voltage	V	24	24	24
Rated power	W	47.1	97.4	144.5
Rated torque	N·m	0.15	0.31	0.46
Rated speed	RPM	3000	3000	3000
Rated current	A	2.7	5.5	8.2
No load speed	RPM	3500	3500	3500
No load current	A	0.29	0.58	0.87
Motor efficiency	%	81.1	82.6	83
Noise (Ambient noise 20db, test distance 1m)	dB	< 50	< 50	< 50
Enclosure - Ambient thermal resistance	K/W	0.57	0.28	0.19
Ambient temperature	°C	30	30	30
Maximum winding temperature	°C	87	87	87
Torque constant	N·m/A	0.056	0.056	0.056
Back-EMF constant / Effective value	V/Krpm	5.87	5.87	5.87
Peak torque	N·m	0.45	0.93	1.38
Peak current	A	8.1	16.5	24.6
Inertia moment	Kg·cm ²	0.22	0.44	0.66

60mm BLDC

Dimensional Drawings

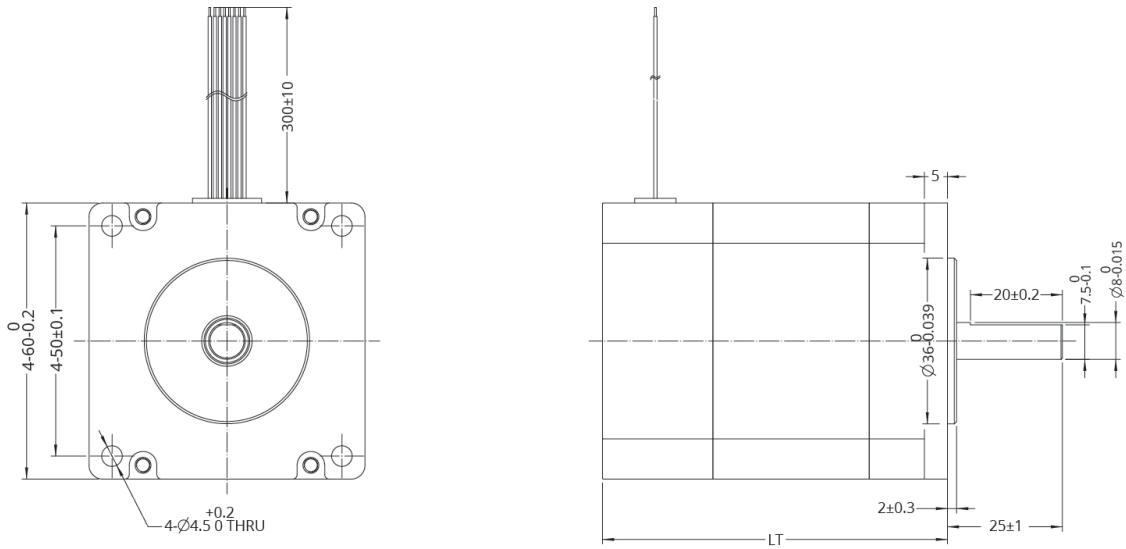

Lead-out type	Lead-out color	Function
UL3265 AWG26	Yellow	Hall U (Hu)
	Green	Hall V (Hv)
	Blue	Hall W (Hw)
	Red	Hall power supply positive (Vcc)
	Black	Hall power supply negative (GND)
UL3265 AWG18	Yellow	U phase
	Green	V phase
	Blue	W phase

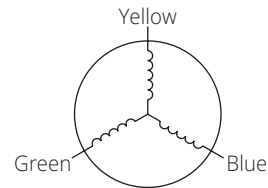
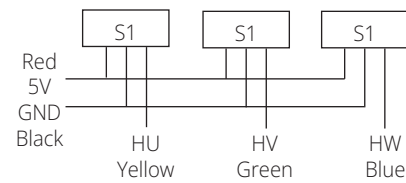

Torque Performance Curves

- 60ZWS50X-1

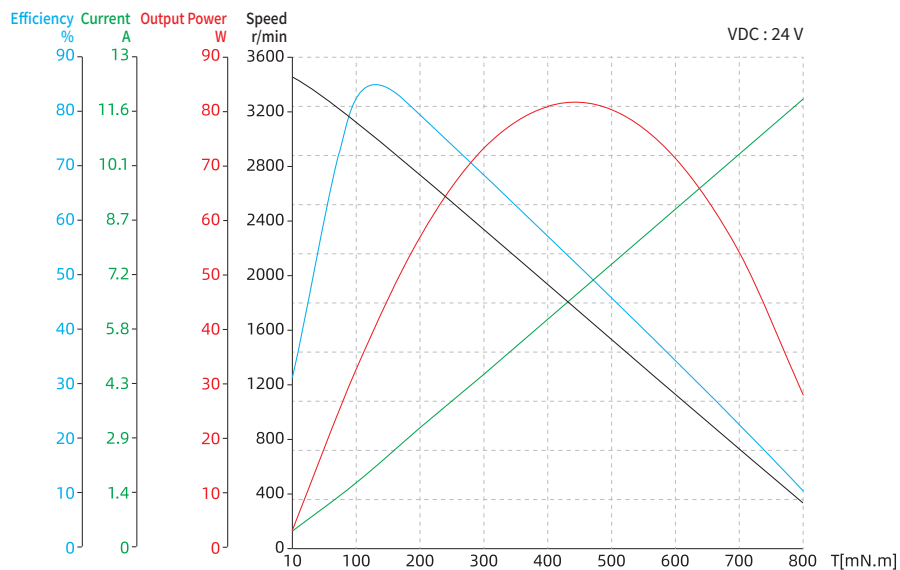

Note : All drawings are 1st Angle Projection - ISO Compliant (3D models available)

60mm BLDC

● 60ZWS63X-1

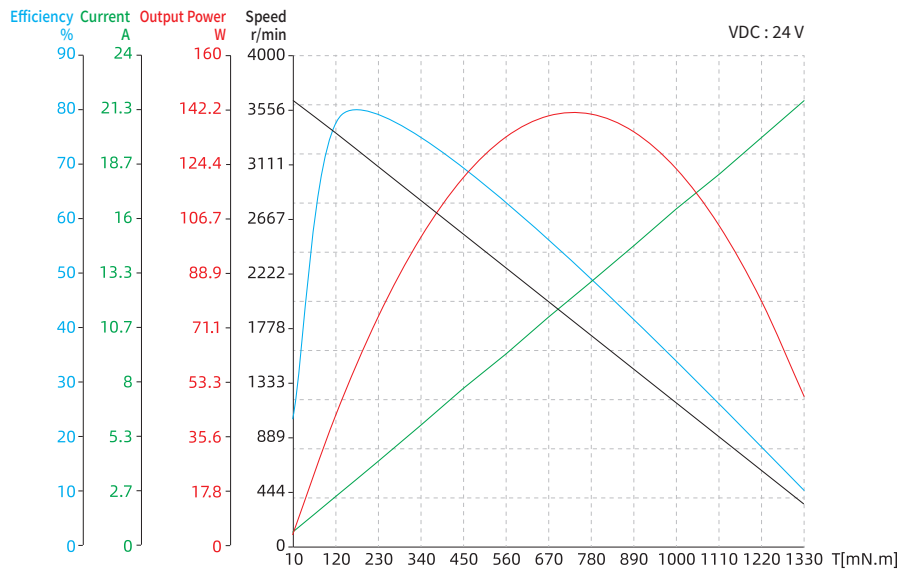

● 60ZWS75X-1

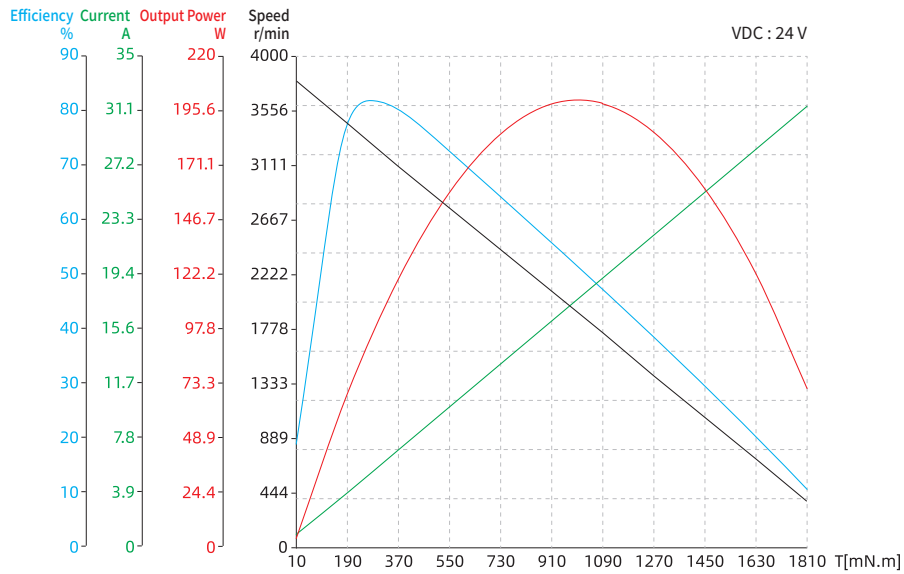

86mm BLDC

86mm Brushless DC Motor has Max. 1.5N·m rated torque and it can generate 471.2W capacity of rated power.

86mm motors have Star winding connection and 5 pole pairs motors with Hall sensors feed back method as standard.

In addition, gearbox and incremental encoder is available.



Motor Characteristics

Motor part number		86ZWS61X-1	86ZWS81X-1	86ZWS101X-1
Body length (LT)	mm	61±1	81±1	101±1
Pole pair	-	5	5	5
Phase resistance	Ω	0.492	0.21	0.13
Phase inductance	mH	1.139	0.44	0.25
Winding connection method	-	Star shape	Star shape	Star shape
Insulation class	-	B	B	B
Duty type	-	S1	S1	S1
Feedback method	-	Hall sensors	Hall sensors	Hall sensors
Commutation angle	-	120°	120°	120°
Insulation strength (Withstand voltage)	-	500VAC/1KHz/ 1mA/1s	500VAC/1KHz/ 1mA/1s	500VAC/1KHz/ 1mA/1s
Insulation resistance	-	100 MOhm 20C	100 MOhm 20C	100 MOhm 20C
Weight	kg	1.38	2.18	3
Rated voltage	V	48	48	48
Rated power	W	157.1	314.1	471.2
Rated torque	N·m	0.5	1	1.5
Rated speed	RPM	3000	3000	3000
Rated current	A	4.7	9.4	14.1
No load speed	RPM	3600	3600	3600
No load current	A	0.35	0.7	1.05
Motor efficiency	%	86.5	85.5	83.7
Noise (Ambient noise 20db, test distance 1m)	dB	< 50	< 50	< 50
Enclosure - Ambient thermal resistance	K/W	0.61	0.31	0.2
Ambient temperature	°C	30	30	30
Maximum winding temperature	°C	90	90	90
Torque constant	N·m/A	0.106	0.106	0.106
Back-EMF constant / Effective value	V/Krpm	11.1	11.1	11.1
Peak torque	N·m	1.5	3	4.5
Peak current	A	14.1	28.2	42.3
Inertia moment	Kg·cm ²	1.4	2.8	4.2

86mm BLDC

Dimensional Drawings

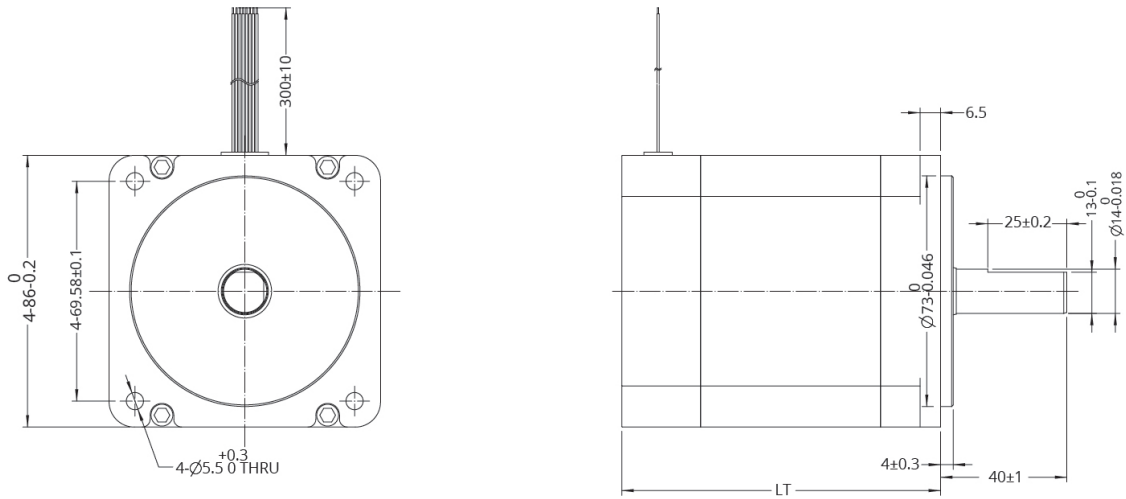

Lead-out type	Lead-out color	Function
UL3265 AWG26	Yellow	Hall U (Hu)
	Green	Hall V (Hv)
	Blue	Hall W (Hw)
	Red	Hall power supply positive (Vcc)
	Black	Hall power supply negative (GND)
UL3265 AWG18	Yellow	U phase
	Green	V phase
	Blue	W phase

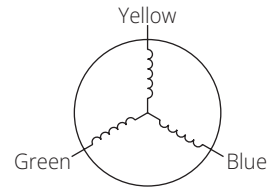
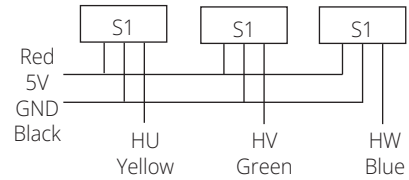

Torque Performance Curves

86ZWS61X-1

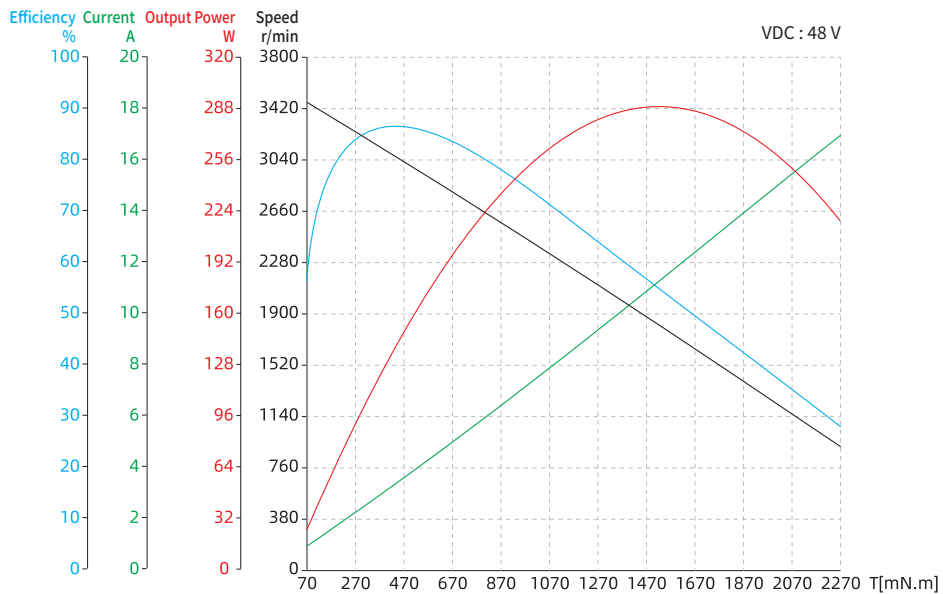

86mm BLDC

● 86ZWS81X-1

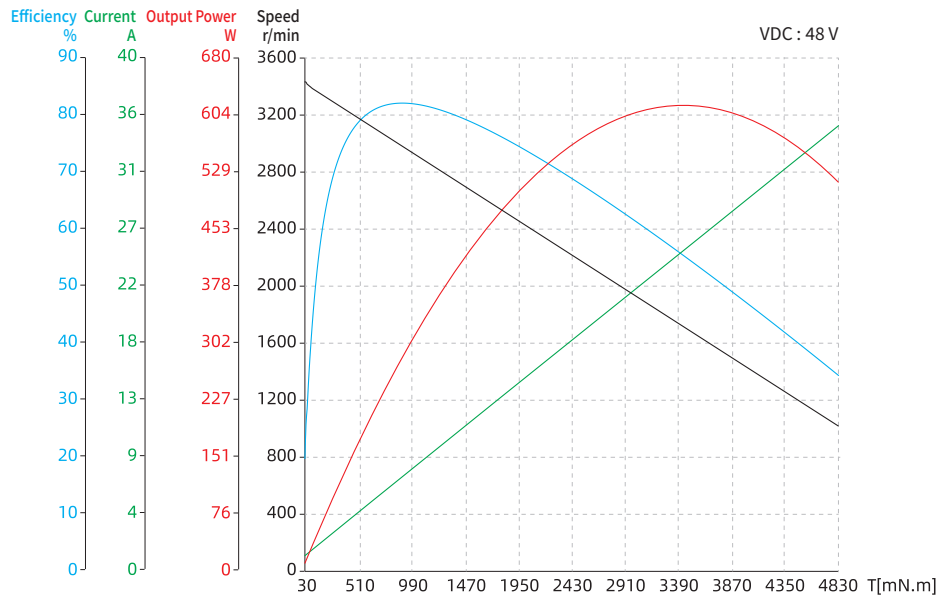

● 86ZWS101X-1

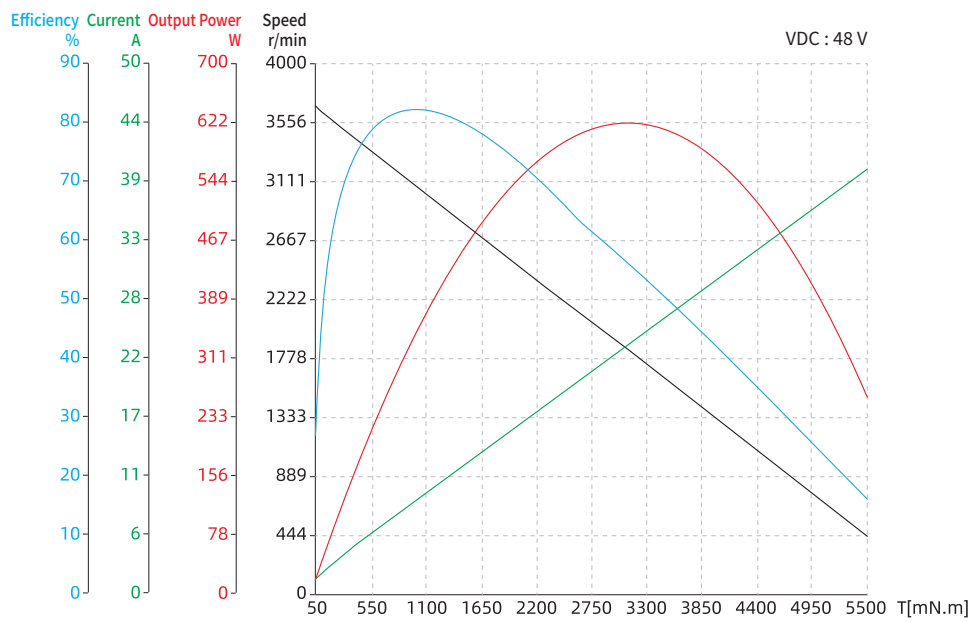

110mm BLDC

110mm Brushless DC Motor has Max. 4.6N·m rated torque and it can generate 710W capacity of rated power.

110mm motor has Star winding connection and 5 pole pairs motors with Hall sensors feed back method as standard.

In addition, gearbox and incremental encoder is available.

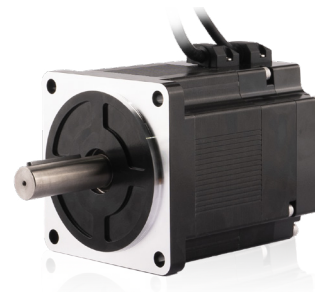

Motor Characteristics

Motor part number		110ZWS132XE-1
Body length (LT)	mm	131±1
Pole pair	-	5
Phase resistance	Ω	1.04
Phase inductance	mH	3.658
Winding connection method	-	Star shape
Insulation class	-	B
Duty type	-	S1
Commutation angle	-	120°
Insulation strength (Withstand voltage)	-	1000VAC/1KHz/1mA/1s
Insulation resistance	-	100 MOhm 20C
Weight	kg	3
Rated voltage	V	120
Rated power	W	710.0
Rated torque	N·m	4.6
Rated speed	RPM	1500
Rated current	A	9.6
No load speed	RPM	1850
No load current	A	0.65
Motor efficiency	%	90
Noise (Ambient noise 20db, test distance 1m)	dB	< 50
Enclosure - Ambient thermal resistance	K/W	0.36
Ambient temperature	°C	20
Maximum winding temperature	°C	88
Torque constant	N·m/A	0.479
Back-EMF constant / Effective value	V/Krpm	67.83
Peak torque	N·m	13.8
Peak current	A	28.8
Inertia moment	Kg·cm ²	10.2

110mm BLDC

Dimensional Drawings

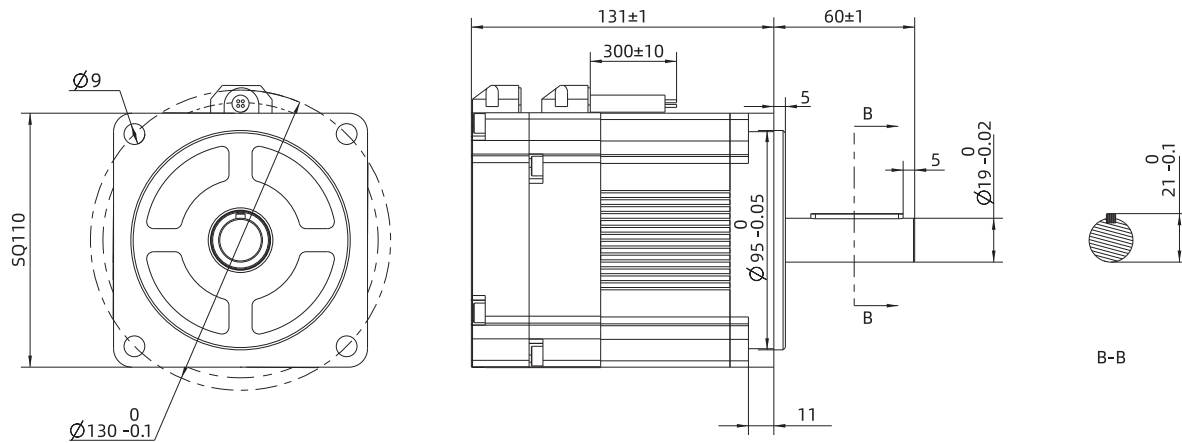

Lead-out type	Lead-out color	Function
UL3265 AWG16	Yellow	U phase
	Red	V phase
	Black	W phase

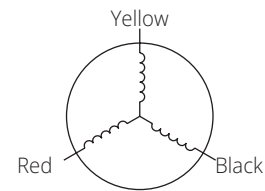

Torque Performance Curves

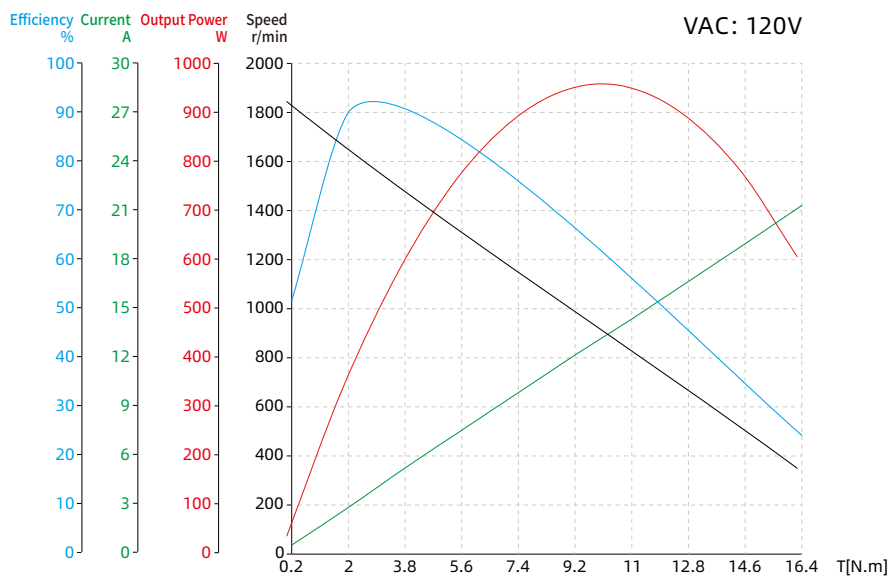

130mm BLDC

130mm Brushless DC Motor has Max. 6.7N·m rated torque and it can generate 701.9W capacity of rated power.

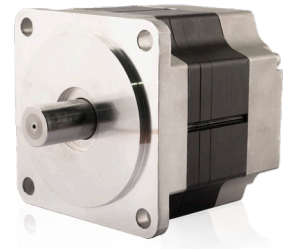

Motor Characteristics

Motor part number		130ZWS126LE-1
Body length (LT)	mm	126
Pole pair	-	5
Phase resistance	Ω	1.04
Phase inductance	mH	3.658
Winding connection method	-	Star shape
Insulation class	-	B
Duty type	-	S1
Commutation angle	-	120°
Insulation strength (Withstand voltage)	-	1000VAC/1KHz/1mA/1s
Insulation resistance	-	100 M Ω /500VDC
Weight	kg	3
Rated voltage	V	120
Rated power	W	701.9
Rated torque	N·m	6.7
Rated speed	RPM	1000
Rated current	A	7
No load speed	RPM	1300
No load current	A	0.6
Motor efficiency	%	83.5
Noise (Ambient noise 20db, test distance 1m)	dB	< 50
Enclosure - Ambient thermal resistance	K/W	0.22
Ambient temperature	°C	20
Maximum winding temperature	°C	94
Torque constant	N·m/A	1.005
Back-EMF constant / Effective value	V/Krpm	112.2
Peak torque	N·m	20.1
Peak current	A	21
Inertia moment	Kg·cm ²	10.2

130mm BLDC

Dimensional Drawings

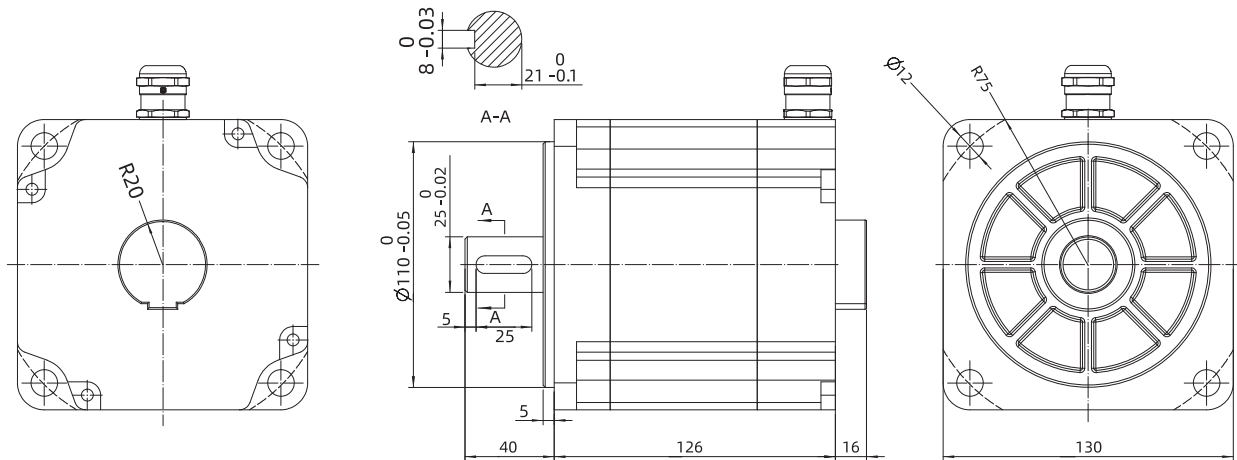

Lead-out type	Lead-out color	Function
AWG16	White	U phase
	Red	V phase
	Black	W phase

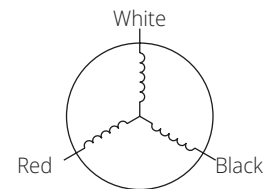

Torque Performance Curves

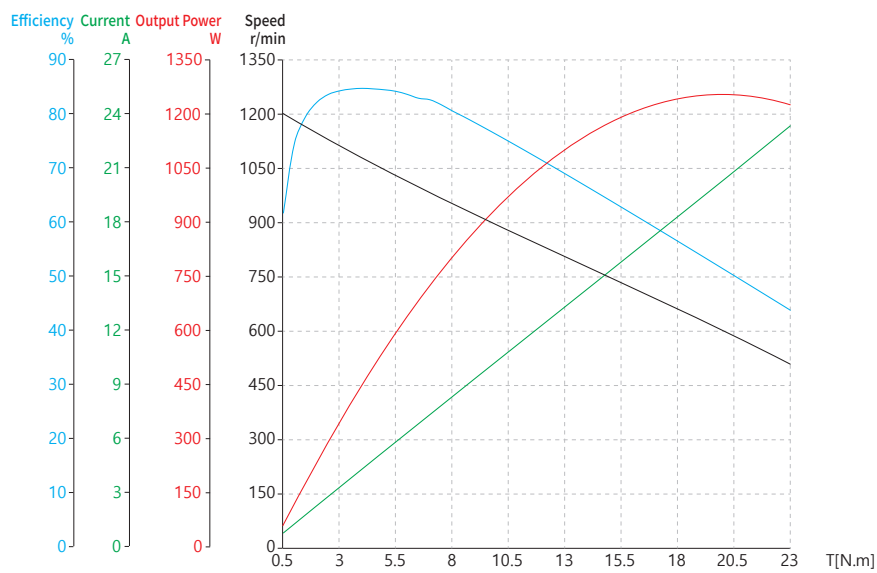

Note : All drawings are 1st Angle Projection - ISO Compliant (3D models available)

Precision Planetary Gearbox

■ Precision planetary gearbox

● 8PGX

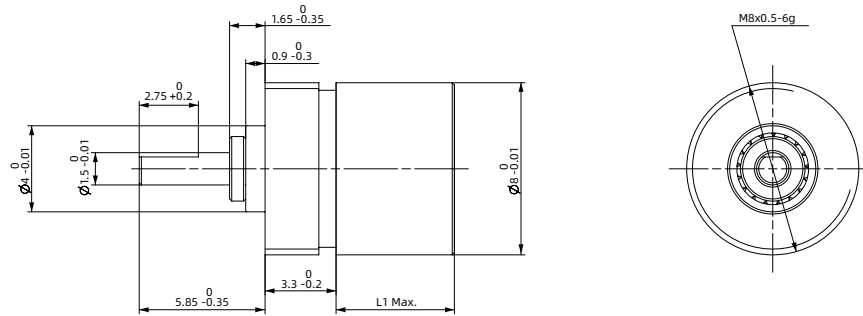

Stage	-	Stage 1	Stage 2
Reduction ratio	X : 1	4	16
Max. continuous torque	N·m	0.01	0.02
Max. continuous output power	W	0.84	0.52
Max. continuous speed transfer	rpm	12000	12000
Max. axial load (Dynamic)	N	5	5
Max. radial load (5mm from flange)	N	5	6
Max. efficiency	%	90	81
Max. backlash	°	1.8	2.0
Gearbox length L	mm	5.5	8.1
Weight	g	2.6	3.2

● 10PGX

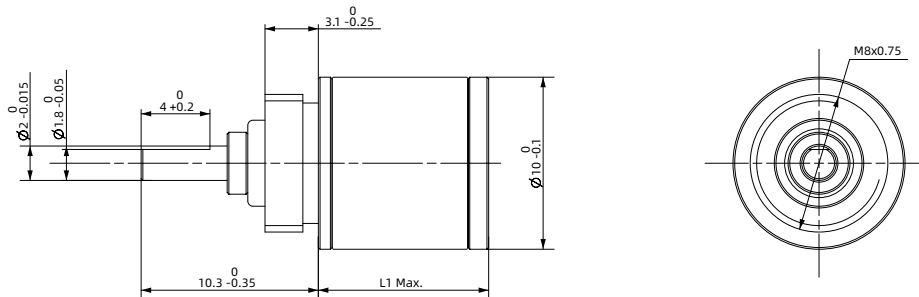

Stage	-	Stage 1	Stage 2	Stage 3	Stage 4
Reduction ratio	X : 1	4.25	18	76.8	326
Max. continuous torque	N·m	0.01	0.03	0.10	0.15
Max. continuous output power	W	1.6	1.2	1.0	0.4
Max. continuous speed transfer	rpm	12000	12000	12000	12000
Max. axial load (Dynamic)	N	5	5	5	5
Max. radial load (5mm from flange)	N	5	10	15	20
Max. efficiency	%	90	81	73	65
Max. backlash	°	1.5	1.8	2.0	2.2
Gearbox length L	mm	10.1	13.6	17.1	20.6
Weight	g	6.7	7.2	7.7	8.2

Precision Planetary Gearbox

● 16PGX

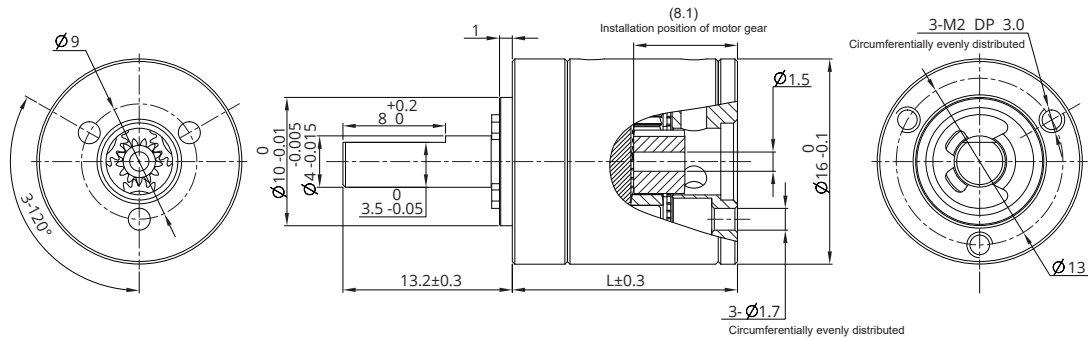

Stage	-	Stage 1	Stage 2	Stage 3	Stage 4
Reduction ratio	X : 1	3.947, 5.307	16, 21, 28	62, 83, 111, 150	243, 326, 439, 590, 794
Max. continuous torque	N·m	0.2	0.25	0.35	0.45
Max. continuous output power	W	6.5	3.2	1.6	0.6
Max. continuous speed transfer	rpm	12000	14000	16000	16000
Max. axial load (Dynamic)	N	20	20	20	20
Max. radial load (5mm from flange)	N	30	45	70	70
Max. efficiency	%	90	80	75	65
Max. backlash	°	1.0	1.2	1.3	1.4
Gearbox length L	mm	18.7	25.5	30.2	35
Weight	g	25	31	37	42

● 22PGX

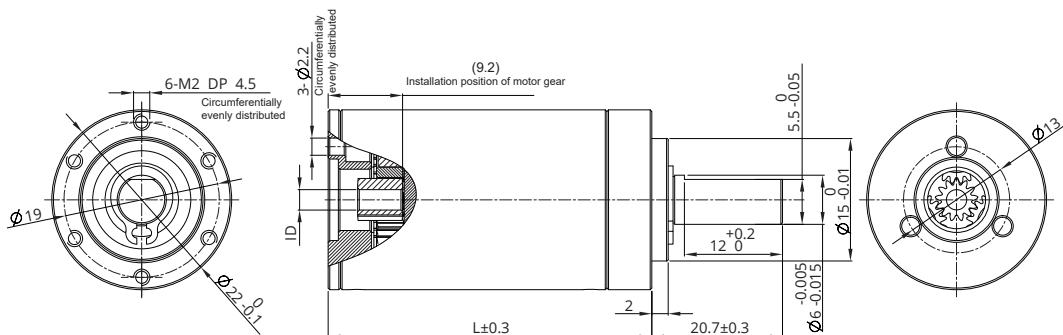

Stage	-	Stage 1	Stage 2	Stage 3	Stage 4
Reduction ratio	X : 1	3.9, 5.3, 6.6	16, 21, 26, 28, 35, 44	62, 83, 103, 111, 138, 150, 172, 186, 231	243, 326, 406, 439, 546, 590, 679, 734, 794, 913, 987, 1135, 1227, 1526
Max. continuous torque	N·m	0.50	0.70	1.20	1.50
Max. continuous output power	W	24	12	6.0	1.6
Max. continuous speed transfer	rpm	8000	10000	12000	12000
Max. axial load (Dynamic)	N	40	40	40	40
Max. radial load (5mm from flange)	N	65	100	120	120
Max. efficiency	%	90	81	74	66
Max. backlash	°	0.85	1.05	1.2	1.35
Gearbox length L	mm	22.3	33	39.6	46.3
Weight	g	59	83	97	112

Precision Planetary Gearbox

● 28PGX

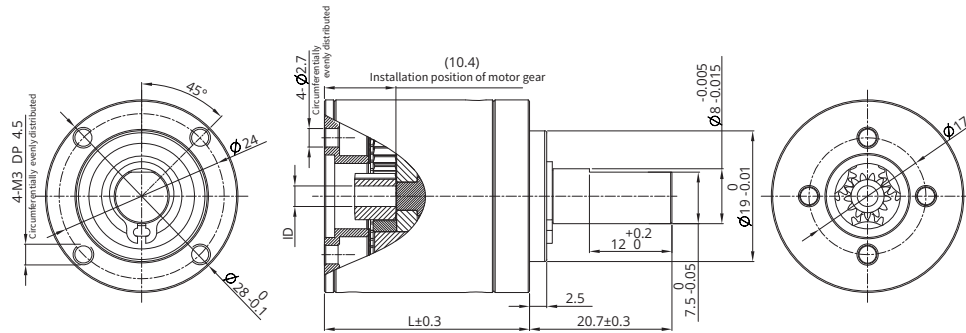

Stage	-	Stage 1	Stage 2	Stage 3	Stage 4
Reduction ratio	X : 1	3.9, 5.3, 6.6	16, 21, 26, 28, 35	62, 83, 103, 111, 138, 150, 172, 186, 231	243, 326, 406, 439, 546, 590, 679, 734, 794, 913, 987, 1135, 1227, 1526
Max. continuous torque	N·m	1.25	2.90	5.0	5.0
Max. continuous output power	W	100	50	25	22
Max. continuous speed transfer	rpm	6000	7000	8000	8000
Max. axial load (Dynamic)	N	110	110	110	110
Max. radial load (5mm from flange)	N	160	180	180	180
Max. efficiency	%	90	81	74	65
Max. backlash	°	0.55	0.7	0.9	1.0
Gearbox length L	mm	24.2	36.9	43.5	50.2
Weight	g	103	150	174	198

● 36PGX

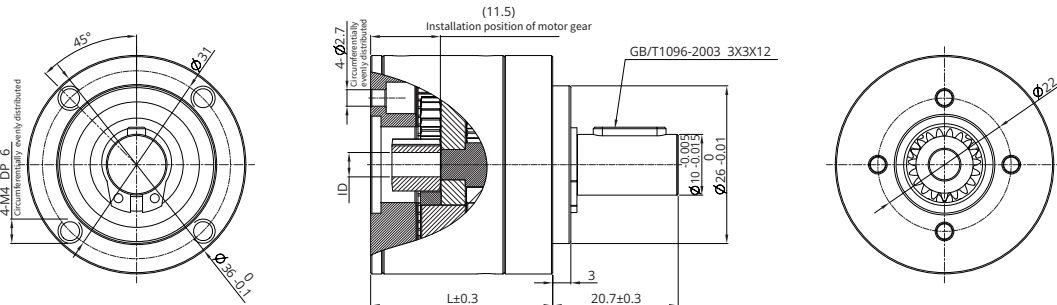

Stage	-	Stage 1	Stage 2	Stage 3	Stage 4
Reduction ratio	X : 1	3.9, 5.3	16, 21, 26, 28, 35	62, 83, 103, 111, 138, 150, 172, 186, 231	243, 326, 406, 439, 546, 590, 679, 734, 794, 913, 987, 1135, 1227, 1526
Max. continuous torque	N·m	2.30	5.40	9.30	9.30
Max. continuous output power	W	185	90	45	40
Max. continuous speed transfer	rpm	5000	6000	7000	7000
Max. axial load (Dynamic)	N	240	240	240	240
Max. radial load (5mm from flange)	N	200	250	250	250
Max. efficiency	%	90	80	75	65
Max. backlash	°	0.5	0.6	0.7	0.8
Gearbox length L	mm	30	44.7	51.3	58
Weight	g	156	238	277	315

Precision Planetary Gearbox

● 42PGX

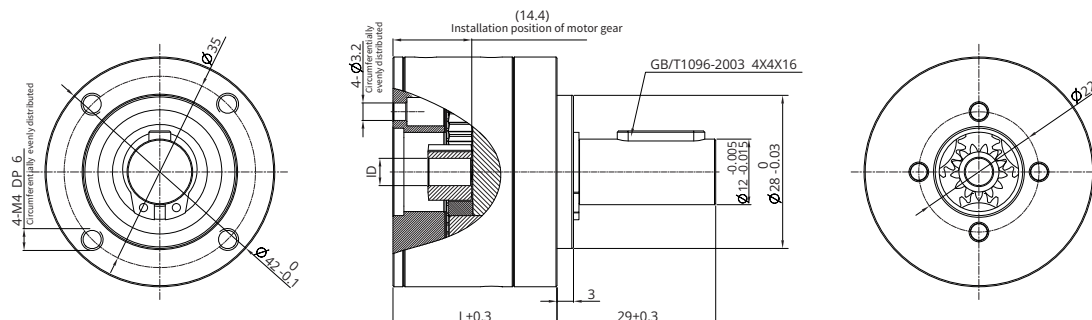

Stage	-	Stage 1	Stage 2	Stage 3	Stage 4
Reduction ratio	X : 1	3.9, 5.3	16, 21, 26, 28, 35	62, 83, 103, 111, 138, 150, 172, 186, 231	243, 326, 406, 439, 546, 590, 679, 734, 794, 913, 987, 1135, 1227, 1526
Max. continuous torque	N·m	3.0	7.5	15	15
Max. continuous output power	W	580	240	100	20
Max. continuous speed transfer	rpm	6000	6000	6000	6000
Max. axial load (Dynamic)	N	200	200	200	200
Max. radial load (5mm from flange)	N	350	525	750	750
Max. efficiency	%	90	81	72	64
Max. backlash	°	0.3	0.4	0.5	0.6
Gearbox length L	mm	36.1	54.9	63.6	72.4
Weight	g	252	405	476	544